

全国首创

First in China



新智特



让科技转动

——新智特纸杯机

温州市新智特机械有限公司

WENZHOU NEWSMART MACHINERY CO., LTD.



## 公司简介 Company Profile

温州新智特机械有限公司成立于2020年，是一家专业从事纸容器成型设备研发、生产的科技创新型企业。公司股东于1999年就开始进入纸容器成型设备生产及研发行业，至今20余年从未间断，公司创始人金海啸先生一直从事于高级工程师职位，从理念设计到调试落地拥有丰富的实地经验。

新智特机械有限公司推出的第一代XZT-150设备拥有多个国内首创打破传统行业的技术壁垒，敢于使用先进的技术替代传统工艺，我们会一直凭借“敢于天下先，才能赢未来”的理念走下去，为行业的革命发展尽一份微薄之力。

Wenzhou New Smart Machinery Co., Ltd was founded in 2020. We are technical innovation enterprise which focus on the paper container forming machinery R & D and production. Our engineers have more than 20 years' experience in the paper container forming machinery manufacturing field. Company founder Mr. Jin Haixiao, also our senior engineer, has rich experience from mechanical design concept to machine commissioning.

New Smart first generation XZT-150 high speed paper cup machine, has several technology barriers which breaks traditional machinery technology. We dare to use advanced technology to instead of traditional technology. We will keep innovation for the revolution of industry's technology.

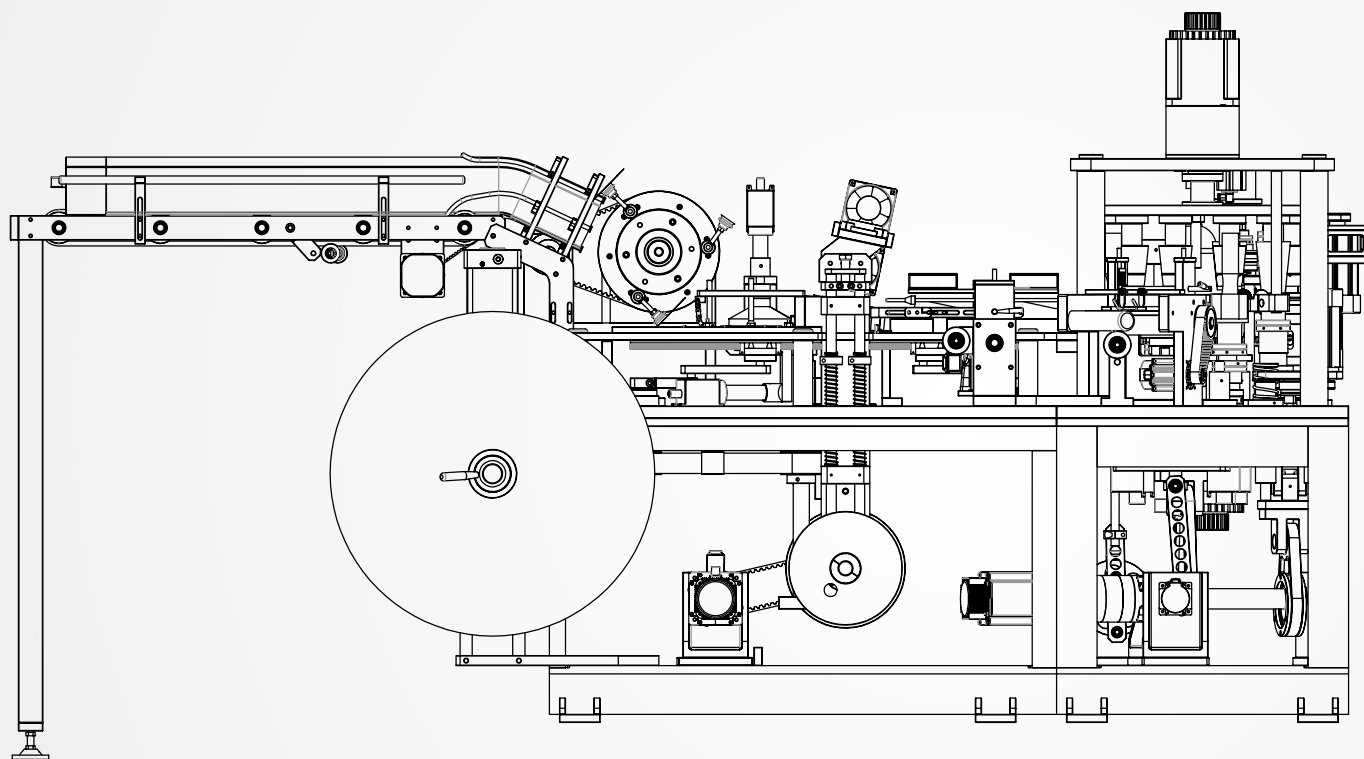

# XZT-150

## FULL SERVO PAPER CUP MACHINE

全伺服纸杯机

发明专利申请号：202011118401.9

### 性能特点

改变了传统纸杯机由链条或齿轮传动的结构，本设备包括吸纸机构，杯体成型机构，翻杯机构，顶杯机构，模具分度机构，杯底成型机构和杯口卷边机构，所有的传动通过独立的伺服电机进行控制其动作，使机器运行的噪音更低，各机构运行动作更加流畅，运行速度和精度更加稳定。

### Features

XZT-150 features full servo driven technology throughout the entire machine. Servo drives work independently to control each station with remarkable accuracy and work together to coordinate the synchronized motion. It replaced the market almost gear / chain transmission and cam design paper cup machine. It provides flexibility, speed, affordable capital cost and low maintenance.

**NEWSMART-200**  
FULL SERVO  
PAPER CUP MACHINE

全伺服纸杯机





## 成品样式 / The finished products



## 主要技术参数 / Main technical parameters

机器型号	MODEL	NEWSMART-200	
产品规格	Cup size	4盎司-16盎司	4-16oz
适用材料	Material	PE/双PE/PLA的淋膜口杯纸、铝箔纸	170-380GSM single or double PE / PLA coated paper 0.25-0.5mm thickness
厚度	Thickness	0.25mm-0.50mm	0.25mm-0.50mm
速度	Speed	180-200Pcs/min	180-200Pcs/min
功率	Power Supply	38KW,实际消耗功率13-15kw/h	3phase 380V 50Hz,38KW (running consumption is 13-15kw/h)
气源	Air Supply	0.6mpa, 实际消耗气压0.4Nm3/min	0.6Mpa (running consumption 0.4Nm3/min)
重量	Weight	3000KG	3000KG
机械尺寸	Dimension	2460长X1620宽X1820高	2460L-1620W-1820H

# XZT-150

FULL SERVO  
PAPER CUP MACHINE

全伺服纸杯机



## 成品样式 / The finished products



## 主要技术参数 / Main technical parameters

机器型号	MODEL	XZT-150	
产品规格	Cup size	4盎司-16盎司	4-16oz
适用材料	Material	PE/双PE/PLA的淋膜口杯纸、铝箔纸	170-380GSM single or double PE / PLA coated paper 0.25-0.5mm thickness
速度	Speed	140-160pcs/min	140-160pcs/min
功率	Power Supply	34Kw,实际消耗功率14kw/h	3phase 380V 50Hz, 34KW (running consumption is 14KW)
气源	Air Supply	0.6mpa, 实际消耗气压0.4Nm3/min	0.6Mpa (running consumption 0.4Nm3/min)
重量	Weight	3000kgs	3000kgs
机械尺寸	Dimension	2460 长x1620 宽x1780 高	2460Lx1620Wx1780H

# XZT-130

国内专供

全伺服纸杯机

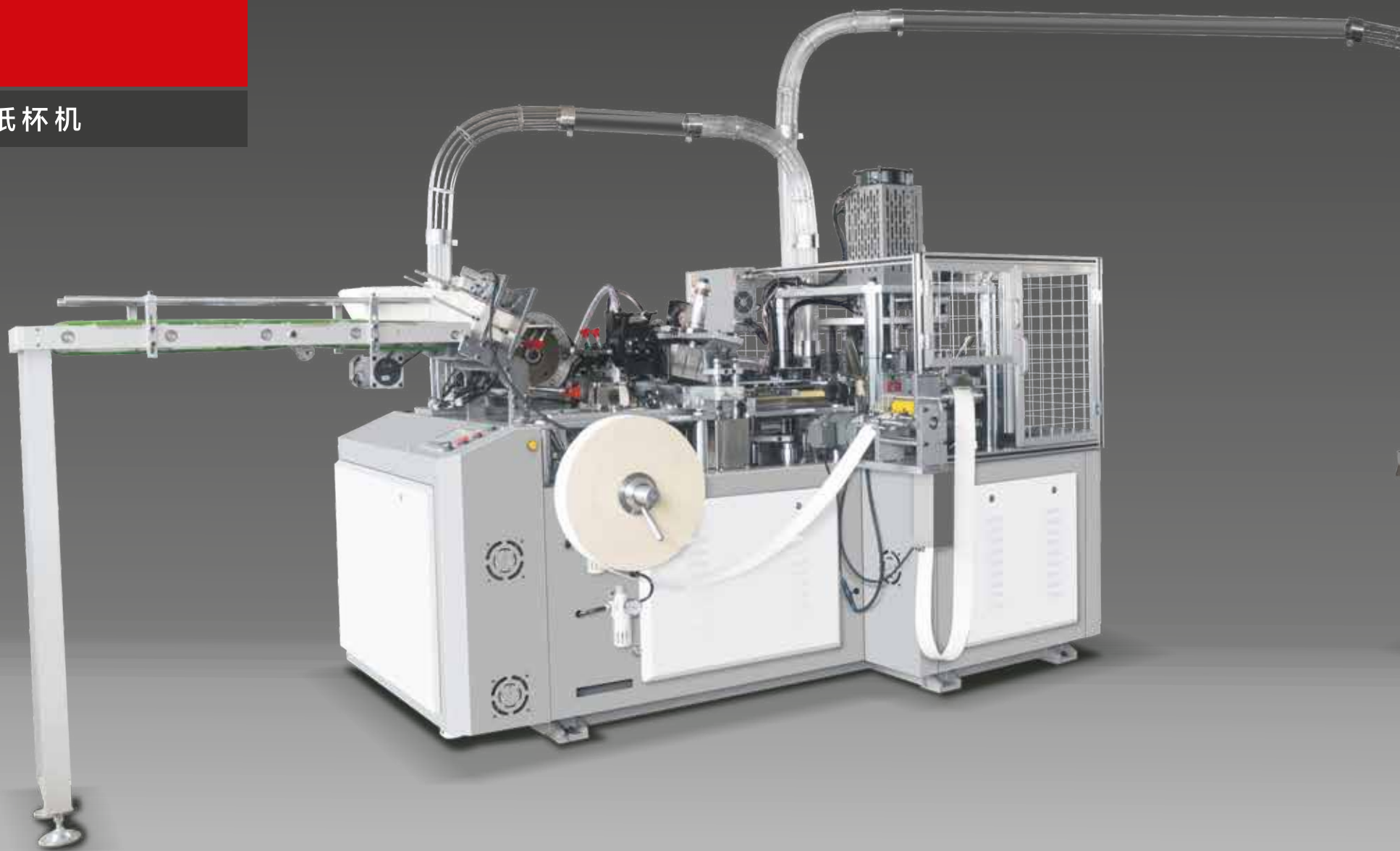



## 成品样式 / The finished products



## 主要技术参数 / Main technical parameters

机器型号	MODEL	XZT-130	
产品规格	Cup size	4盎司-16盎司	4-16oz
适用材料	Material	PE/双PE/PLA的淋膜口杯纸、铝箔纸	170-380GSM single or double PE / PLA coated paper 0.25-0.5mm thickness
速度	Speed	130-150pcs/min	130-150pcs/min
功率	Power Supply	34Kw,实际消耗功率14kw/h	3phase 380V 50Hz, 34KW (running consumption is 14KW)
气源	Air Supply	0.6mpa, 实际消耗气压0.4Nm3/min	0.6Mpa (running consumption 0.4Nm3/min)
重量	Weight	3000kgs	3000kgs
机械尺寸	Dimension	2460 长x1620 宽x1780 高	2460Lx1620Wx1780H

# XZT-150W

FULL SERVO  
PAPER BOWL MACHINE

全伺服纸碗机



## 成品样式 / The finished products



## 主要技术参数 / Main technical parameters

机器型号	MODEL	XZT-150W	
产品规格	Cup size	16盎司-57盎司	16-57oz
适用材料	Material	PE/双PE/PLA的淋膜口杯纸、铝箔纸	170-380GSM single or double PE / PLA coated paper 0.25-0.5mm thickness
厚度	thickness	0.25mm-0.50mm	0.25mm-0.50mm
速度	Speed	120-150pcs/min	120-150pcs/min
功率	Power Supply	44Kw,实际消耗功率18kw/h	3phase 380V 50Hz, 44KW (running consumption is 18KW)
气源	Air Supply	0.6mpa, 实际消耗气压0.5Nm3/min	0.6Mpa (running consumption 0.5Nm3/min)
重量	Weight	4500kgs	4500kgs
机械尺寸	Dimension	2760 长x2160 宽x1925 高	2760Lx2160Wx1925H

# BZJ-800

FULLY AUTOMATIC INTELLIGENT  
PACKAGING MACHINE

全自动智能包装机



## 包装生产线流程示意图 / Schematic Diagram Of The Packaging Production Line

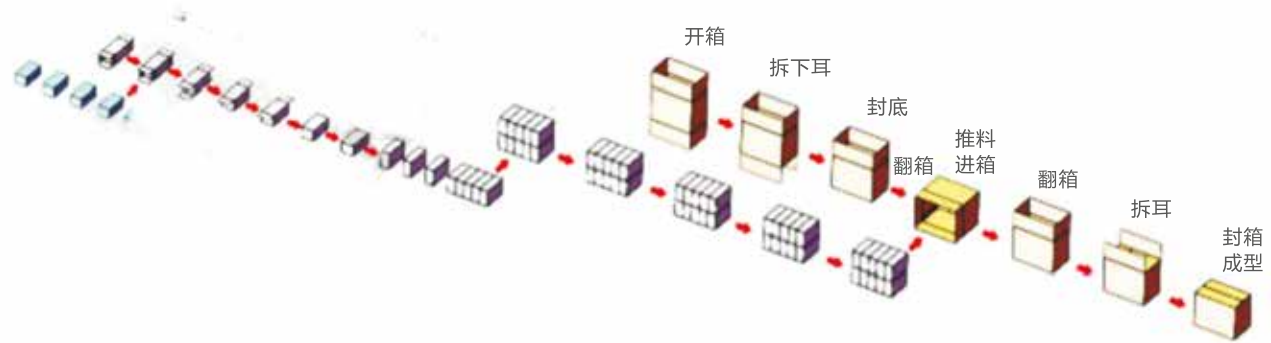

### 主要技术参数 / Main technical parameters

机器型号	MODEL	开箱机主要配置	项目名称	自动开箱、装箱(含理料)、一字封箱、工字封箱
电源	power supply	220V/50Hz	客户需求	1、纸箱尺寸：580*400*380mm (物料尺寸：380*70*70mm) 2、来料速度：18条/分钟 3、工艺要求：接驳前端来料 4、装箱形式：工字封，40条/箱 (8条*5层) 5、工字封箱 6、来料方向：从左往右
功率	power	400W		
气压	air pressure	6kg/ cm2		
机器外形尺寸	Machine dimensions	L2000mm×W1950mm×H1500mm		
胶带宽度	Tape width	4.8-7.2cm		
单机生产效率	Single machine production efficiency	≥95%		
开箱方式	Out of the box	立式成型		

机器型号	MODEL	封箱机主要配置	机器型号	MODEL	装箱机主要配置
电源	power supply	220V/50Hz	电源	power supply	220V/50Hz
功率	power	200W	功率	power	1-4Kw
气压	air pressure	6kg/ cm2	适用纸箱	Applicable carton	待客户确认
机器外形尺寸	Machine dimensions	L1700mm×W1930mm×H1500mm	装箱速度	Packing speed	1-2箱/分钟
台面高度	table height	600mm (可调)	重量	weight	约1.5T
皮带速度	Belt speed	20米/分			
胶带尺寸	Tape size	48、60mm 择一			
	Belt height				



# GC-120A

FULL AUTOMATIC  
PACKING MACHINE

全自动立式包装机



## 机器展示 / The machine display



## 主要技术参数 / Main technical parameters

机器型号	MODEL	GC-I20A	
薄膜种类	Type of film	OPP / PE / PP / POF	OPP / PE / PP / POF
薄膜厚度	Packaging film thickness	10-30微米	10-30um
包装排数	Option row	单道包装	Single
包装速度	Speed	10-15袋/分钟	15pcs/min
最大包装长度	Bag length	600毫米	600mm
杯子直径	Cup diameter	50-140毫米	50-140mm
功率	Total power	2.4千瓦	2.4KW
气量	Air source	0.5千帕	0.5mpa
机械尺寸	Mechanical dimensions	2100长X1300宽X1800高	2100LX1300WX1800H
整机重量	Machine weight	500公斤	500KG

敢为天下先，才能赢未来

 浙江省温州市平阳县海西镇陡北村A-01-01地块  
A-01-01 Plot DouBei Village, HaiXi Town, PingYang County,  
WenZhou City, ZheJiang Province, China

 **189 6898 8112**

 **0577-6675 5511**

 [newsmart@xinzhitejx.com](mailto:newsmart@xinzhitejx.com)

 [www.xinzhitejx.com](http://www.xinzhitejx.com)